

# Technical Specification

REF: PWB1

ISS: 1

## Key Features

- LED High Power 60 cd Output
- Multiple Flash Patterns
- 10 – 30 Volt Operation
- Mag Mount & Bolt Fix Options
- Small Package Size - 60mm High

## Technical Specification

**Functions:** Amber Warning with 360 Degree Illumination

**Homologation:** REG 10

**Voltage:** 10 – 30 Volts

**Power Consumption :** 4.5w

**Connection :** 500mm Cable / Auxiliary Plug + 500mm Cable

**Fixing :** Magnetic or Bolt Mount

**IP Rating :** IP65 Hermetically Sealed

**Material :** Lens – PC / Housing - PC

**Temperature Range :** -30°C to +65°C

## Part Numbers

PL.345.S.02 LED Mini Beacon 10 – 30 Volt Mag Mount + Cable + Plug

PL.345.S.03 LED Mini Beacon 10 – 30 Volt Bolt Mount

**NOTE:** Option of Clear Lens by request

## See Also

PL.135.S.02 Beacon LED 10-30 Volt Mag Mount + Cable + Plug

PL.135.S.03 Beacon LED 10-30 Volt Bolt Mount + Cable

## 345 Series - LED Mini Beacon



### Overview

Ultra LED Warning Light with 360 Degree Visibility for Warning & Safety applications. Housed within a small package design helping prevent accidental damage during operation. Overall Height only 60mm.

Magnetic or 3 Bolt Fixing options available.

### Drawing

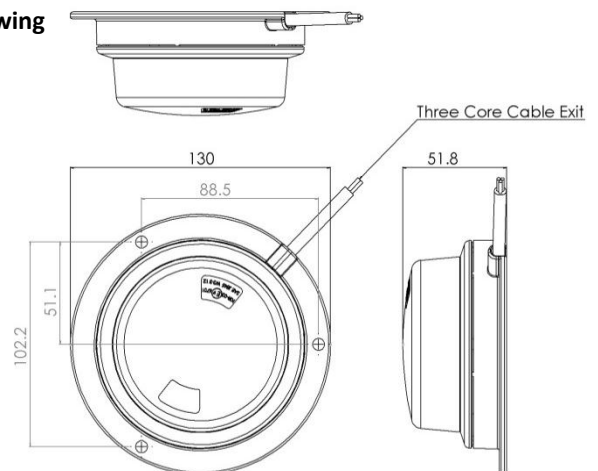

www.perei.co.uk | sales@perei.co.uk | +44 (0) 1842 812290

Perei Group Limited | Keystone Innovation Centre | Thetford | Norfolk | IP24 1JD | United Kingdom

Specifications herein are subject to change without notice

**PEREI**